



1st Term 2023 Holiday-Package

P.6 ENGLISH LANGUAGE.

NAME _____ STREAM _____

A	
B	
T	

SECTION A

In questions 1-5, fill in the blank spaces with the most suitable word.

1. _____ should walk along the pavements.
2. _____ is your best cyclist?
3. He is _____ a cyclist nor a motorist.
4. The passengers paid their _____ at once before they left the taxi.
5. The _____ they chose for debate was rather interesting.

In questions 6-15, use the correct form of the word in brackets to complete the sentences.

6. Her _____ pleased the on lookers. (honest)
7. Because of Ruth's _____, she was rewarded on the assembly. (clean)
8. Joan is the _____ in the queue. (forty)
9. Anna's point of _____ raised many suggestions. (inquire)
10. Teach them the correct _____ of that word. (pronounce)
11. No sooner had the mainspeaker _____ than we all kept quiet. (go)
12. Immediately they _____ the snake, they made a lot of noise. (see)
13. They have never _____ that Anthem. (sing)
14. They were advised not to commit any _____ offence. (crime)
15. Mary _____ up confidently and gave out her points. (stand)

In questions 16-17, Use the given words to make one meaningful sentence from each.

16. debt
-

17. debate.
-

Re-write the sentences 18-20, giving one word for the underlined group of words.

18. The topic for debate was too wide.
-

19. The cyclist put on the hard cap on his head hurriedly.

Re-write the sentences giving the plural of the underlined words.

20. Our motto is purity and no pain no gain.

21. Peter counted one cow from the heard.

Re-write the sentence giving the opposite of the underlined words.

22. Their guest was too smart.

23. Her cleanliness surprised us.

Re-arrange the words below to make meaningful sentences

24. Pavements walk the pedestrians along.

25. debate secretary points down A main a in writes.

Write the following in full.

26. Hon. _____

27. Shan't. _____

Re-arrange in correct alphabetical order.

28. driving, drive, driver driven.

29. elements , element, helmet, elementary.

30. sport, spur, speak, spit.

Re-write the sentences as instructed in the brackets.

31. Who is your class teacher Joseph asked. (Re-write and punctuate correctly)

32. The policeman saw the driver. The policeman stopped the driver.
(Begin: Immediately)

33. We crossed the road. The road was clear.(Use.....as soon as)

34. The pedestrian saw the mad man. The pedestrian ran. (Begin: No sooner.....)

35. The chairperson stopped the audience. The audience was making noise.
(Usebecause of.....)

36. Namuli was rewarded. Namuli was clean. (Join using..... due to.....)
-
-
37. John did not see the thief. Mary did not see the thief. (Join using.....and neither.....)
-
-
38. You put up your hand. The chairperson will not choose you.
(Begin: Even though.....)
-
-
39. The driver is at the police. The driver's car got an accident.
(Join as one sentence using.....whose.....)
-
-
40. It is difficult to work with lazy members. (Begin: How.....)
-
-
41. They stole two oranges from the basket. (Re-write the sentence in interrogative)
-
-
42. She is not too far from the truth.(Re-write the sentence as an affirmative)
-
-
43. She speaks English fluently. (Re-write and add a correct tag)
-
-
44. Joan is fat. Ruth is fatter. (Join using.....not as.....)
-
-
45. The secretary will not write down your points. You have to explain each point.
(Begin: Unless.....)
-
-
46. The driver was fast. The pedestrian could not identify the driver.
(Join using:.....too.....to.....)
-
-
47. The main speaker is audible. Everyone can get her points.
(Join usingsuch an.....)
-
-
48. We stood at the back. We wanted to hear the secretary's summary.

(Join using.....so that.....)

49. She counted a scarf during her exercise. (Re-write the sentence into plural)

50. He returned the book to the person in charge of the library.
(Re-write the sentence giving one word for the underlined group of words)

SECTION B.(50 Marks)

51.Read the passage below and in full sentence, answer the questions that follow.

One Monday morning, the people of Kitalo village woke up in the happy mood as usual by 8.00 o'clock in the morning, all the adults were in the gardens cultivating their pieces of land. The rainy season had just started so they were busy. The children were at school. This was the order of the day in their village.

By around midday, shock filled the village. It started as a rumour that a fatal accident had occurred along Nkolimbo road .Then the news spread all over the radio stations. A speeding taxi had overturned. Four people had died on spot. People rushed to the scene of accident to witness the situation on the ground. Some rushed there to help the casualties. Others only ran there to gaze and gather news they would spread. However, there are those who came to rob the victims. They picked any property that had scattered all over the place. They showed no mercy and sympathy to the people who were bleeding and dying.

The situation only normalized when the police arrived. According to the people who were present at the time of the accident, they blamed it on the taxi driver. He was over speeding yet that place is a black spot. It has a blind bend. Worse still, this driver was drunk,the survivors reported.

More shocking to the sad news, was the fact that two of the accident victims were from this village. They had just boarded the taxi about a kilometer away from the scene of the accident. What a sorrowful moment the villagers had.

Questions

a. What is the passage about?

b. What is the main occupation of the people of Kitalo village?

c. Why were people sad on that day?

d. Where did the accident take place?

e. According to the passage, what caused the accident?

f. How many people from Kitalo village died?

g. Which people were merciless according to the passage?

h. Who do you think chased away the thieves?

i. Give another word which means fatal as used in the passage.

j. Suggest a suitable title to the passage.

52. The sentences below are in wrong order. Re-arrange them to form a good story.

- a. The shop attendant will give you a card.
- b. This card contains a secret number covered by a silver seal.
- c. After pressing *130*, the secret number and #, press the call button.
- d. Ask the shop attendant for the airtime of your choice.
- e. You will see a short message on your phone screen.
- f. If it is Airtel, press *130*, the secret number and #.
- g. This is how Airtime is loaded on a simcard.
- h. This message will be showing you how much airtime you have loaded.
- i. First run to the shop.
- j. Scratch the silver seal in order to see the secret number.

53. Read the poem below and answer the questions that follow in full sentences.

Mechanic ! Mechanic!
Dressed in a blue overall.
Carrying a toolbox with with him,
Full of spanners, pumps and nuts.

Mechanic ! Mechanic!
Working on his customers' vehicles with care.
Those with engine problems, he handles with ease.
The one with punctures, rubber solution does it all.

Mechanic ! Mechanic!
So great you are!
Without your work,
We wouldn't drive

Kirungi Liz (P.6)

Questions:

a. What is the poem about?

b. What does the mechanic wear?

c. If you want a spanner, where do you find it?

d. Why do you think the mechanic is important?

e. Mention the tools a mechanic uses to fix people's vehicles.

f. What does the mechanic use to repair tyres with punctures?

g. Why do you think the mechanic is so great?

h. In which class is the writer of the poem?

i. Give one word which has the same meaning as:
with ease: _____

j. Suggest a suitable title to the poem.

54. Read the poster below and answer in full sentences the questions that follow.

DEBATE

DEBATE

DEBATE

Zombo p/s versus Katawi Town Academy

Fri: 20th November, 2012.

Venue: Katawi Town Academy Mainhall

Time: 2:00p.m-5.00p.m

Motion: Girl Child Education Is a Must

Opposer: The hosting school

Proposers : zombo Primary school

 Mr. Mugamba,

 Head of department

Questions.

a. What is the notice about?

b. How long will the debate take?

c. When will the debate take place?

d. Where will the debate take place?

e. What is the motion of the debate?

f. At what time will the debate start?

g. Who wrote the notice?

h. Write another word that means the same as:

i. motion

ii. debate:

i. Which school will oppose the motion?

55. The letter below was written by Kizza Jane. Read it carefully and fill in the blank spaces with suitable words to make it complete.

(1) _____

P.O.BOX 23,

Kisubi.

(2) _____

Dear (3) _____,

It's been a while (4) _____ I last talked to you. How are you mother? How are you doing with the business ? I am surely alive and kicking.

I have (5) _____ to you this letter to express my (6) _____ for the care you give me and for the (7) _____ you paid for me to be at school. I am indeed (8) _____. please, mummy I would like to let you know that I love you so much. I always (9) _____ to God to keep you alive.

My God bless you ,mother.

Your daughter,

(10)_____



1st Term 2023 Holiday-Package

P.6 MATHEMATICS

Time allowed: 2hours 30minutes

Name: Stream:.....

SECTION A (40 MARKS)

1. Work out:

$$\begin{array}{r} 20 \\ - 9 \\ \hline \end{array}$$

2. Write 4031 in words.

3. Given that $M = \{\text{boy}\}$. Find the number of subsets in set M.

4. Write down the number shown on the tens abacus and complete it.

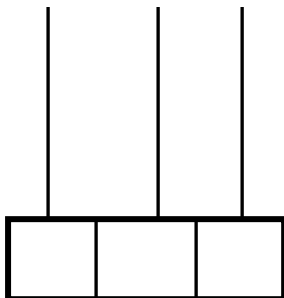

5. Express CXCIX in Hindu Arabic Numerals.

6. Round off 13, 853 to the nearest thousands.

7. Find the value of y in the figure.

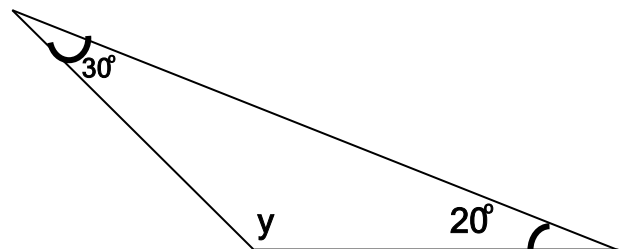

8) Simplify: $\frac{2}{3} + \frac{3}{4}$

9) Given that $Q = \{1, 2, 3, 4, 5\}$ and

Find $n(Q \cup R)$ where $R = \{2, 4, 6, 8\}$

10. Divide: 2424 by 6

11. Find the prime factorization of 36 in a power form.

12. In a class of 72 pupils, $\frac{5}{8}$ are girls and the rest are boys. Find the number of girls in that class.

13. In a box, there are 12 black pens. 8 red pens and 6 blue pens. Find the probability that Kamau picks a red pen.

14. Find the sum of the first 4 prime numbers.

15. Write in figures: four hundred three thousand six hundred four.

16. Draw and give the number of lines of symmetry the shape has

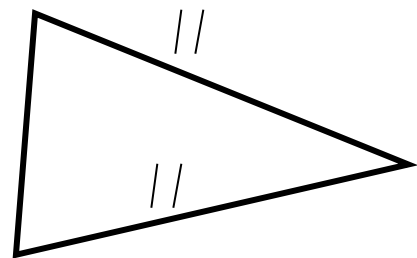

17. Find the square root of 16.

SECTION B

18. Solve: $2x - 8 = 0$

19. 3 pens cost sh. 900. How many pens would be bought using sh. 2400?

20. Study the Venn diagram below and find $n(k^1)^0$

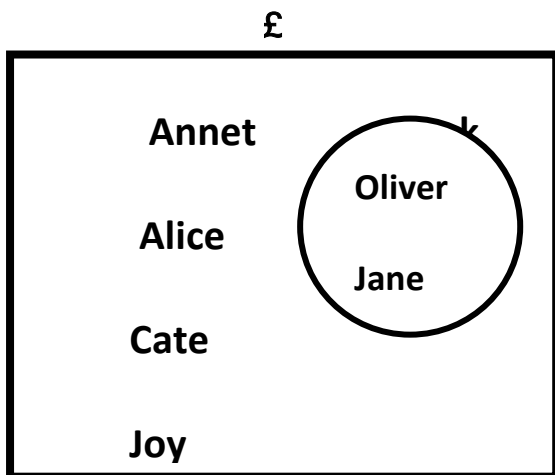

21. In a class of 72 students, 50 students passed mathematics (M), 60 students passed English (E), x students passed both subjects and 3 students failed both.

a) Complete the Venn diagram.

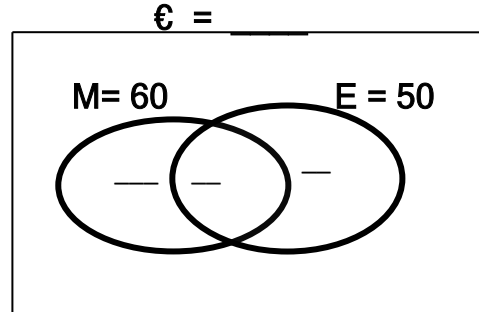

b) How many students are represented by letter x.

c) Find the number of students who passed only on subject.

22. The transport fare from Entebbe to Kampala is sh. 2500 and sh.3000 from Kampala back to Entebbe in a taxi. If the taxi has 4 seats of 3 passengers each;

- a) Find the maximum number of passengers the taxi can take a time.

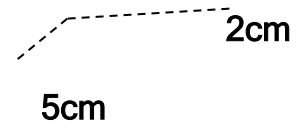

- a) Find its volume.

- b) How much money is collected from all the passengers from Entebbe to Kampala when its full to capacity?

- b) Find its total surface area.

- c) If the taxi goes and comes back when it is full to capacity find the total amount of money collected from all the passengers.

- c) How many edges does it have?

23. Study the cuboid and answer the questions about it.

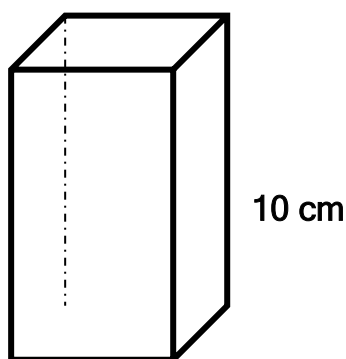

- 24a) Arrange $\frac{1}{2}$, $\frac{1}{4}$, $\frac{2}{3}$ in ascending order.

b) Work out: $\frac{3}{4} - \frac{1}{5}$

25. Study the number line and write the integers shown by the arrows on the number line.

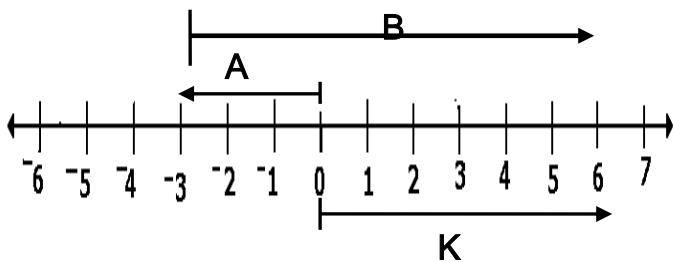

Arrow A = _____

Arrow B = _____

Arrow C = _____

c) Write the mathematical statement shown by the arrows on the number line.

26a) Given that;

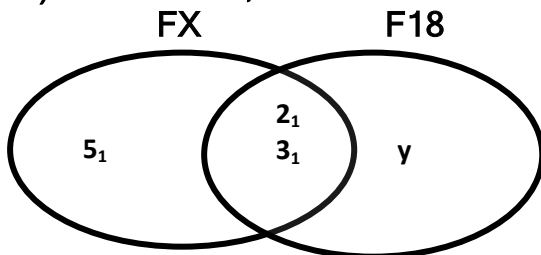

a) Find the G.C.F of X and 18.

b) Find the value of y.

c) Find the L.C.M of X and 18.

27. A pupil scored the following marks out of 10.

7, 8, 6, 8, 9, 7, 8, 6, 8, 3

a) Find it's average mark.

b) Find the modal mark

c) Find the median mark.

28. A girl tossed a die in a Ludo game find the probability that;

a) An even number showed up.

b) John is 3 years older than Tom. If Tom is 8 years. How old is John?

b) A number greater than 2 showed on top.

c) A factor of 6 showed on top.

29a) If $a = 2$, $b = 6$ and $c = 3$

i) Evaluate $a + b + c$

ii) Find the value of $\frac{bc}{a}$

30. Find the size of angle y .

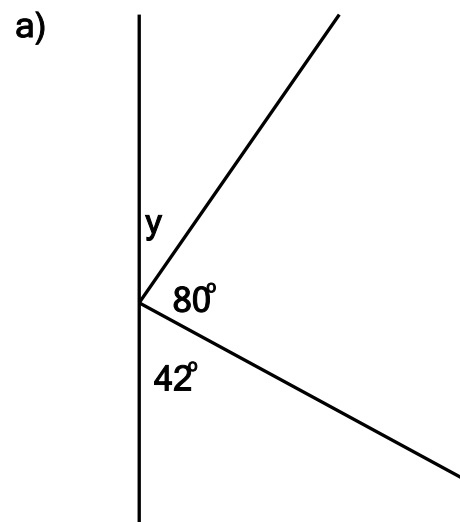

b)

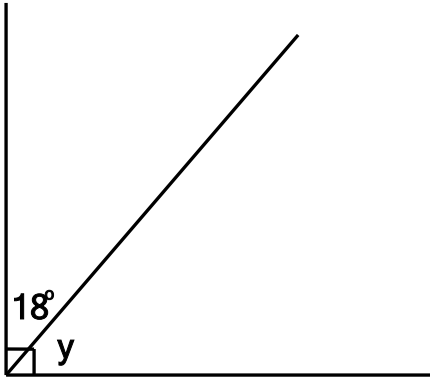

b) If she remained with sh.420, how much money did she have before?

31a) A school girl bought the following items.





-2 dozens of books at sh. 6000 per dozen.

- $\frac{1}{2}$ kg of salt at sh. 2000 a kg

-4 pens at sh. 2800

a) Find her total expenditure.

32. The table shows the number of apples a trader sold in five days.

Days	Number of Apples
Mon	
Tue	
Wed	
Thur	
Fri	

- If  stands for 5 apples,
- a) When was the smallest number of apples sold?
- b) Find the range between the number of apple sold on Wednesday and Friday.
- c) How many apples were sold in the five days altogether?



1st Term 2023 Holiday-Package
P.6 SOCIAL STUDIES

NAME: _____ STREAM: _____

SECTION A: (40 MARKS)

1. Musana wanted to find the direction of Kisubi Girls' from Kampala. Which instrument can she use?

2. Give one reason why people are not allowed to settle in wetlands.

3. Mention the social service provided by Doctors.

4. In what way does man benefit from water sources near him?

5. Name the official language spoken in offices and schools of Uganda.

6. What made Dr. Louis Leakey important in the history of East Africa?

7. Name the traditional ruler in Uganda who refused the formation of East African Federation.

8. What makes Rwanda to be a landlocked country?

9. Identify one country which is still a new member of the East African Community.

10. State one reason why people migrate today.

11. Identify one form of child abuse observed in Uganda today?

12. In which way is Kasubi tombs important to Buganda kingdom?

13. Suggest one way a school needs a library.

14. In which one way do parents help the government to promote U.P.E and U.S.E?

15. Of what economic importance are Stone Age sites to a country?

16. What aspect on the coat of arms shows that God loves your country?

17. Suggest one reason why man has destroyed the natural vegetation of Uganda.

18. If a teacher wanted to set up an industry on Ssesse Islands, What industry would you advise him to set up?

19. Identify one way the discovery of fire changed the early man's way of life.

20. Identify the problem people who live a long Mt. Elgon face as a result of heavy rainfall.

21. State one common problem Uganda shares with Rwanda in carrying out international trade.

22. How was the discovery of iron smelting important to the early man?

23. In which one way is the East African Community beneficial to the member countries.

24. State the difference between lines of latitudes and lines of longitudes.

25. Mention any one national symbol of Uganda that is the same as that of Tanzania, Kenya and Burundi.

26. Give at least one factor that made the Nilotics change from pastoralism to mixed farming after settlement.

27. A part from sunny season, under which other weather condition does one use an umbrella.

28. Where do we find the headquarters of the East African Community?

29. What is meant by the term agro- based industries?

30. Identify one raw- material used in making cement.

31. State one cause of road accidents.

32. Suggest the major reason why Arabs came on the East African Coast?

For Questions 33-40 answer Either Christianity Or Islam BUT NOT BOTH in one number.

33. Either: Give one reason why Christians fast during lent season.

Or: suggest one reason why Moslems fast during the month of Ramadhan?

34. Either: Why do Christians celebrate Easter Sunday?

Or: Why do Moslems celebrate Idi- eli- fitri?

35. Either: Why did Jesus die on the cross?

Or: Why did Allah create man in his image?

36. Either: Give one reason why Christians pray to God.

Or: Why do Moslems pray 5 times daily?

37. Either: How did God fulfill His plan of man's salvation?

Or: In which one way does one become a Moslem?

38. Either: What should a Christian do when he breaks one of the 10 commandments?

Or: What should a Moslem do when he breaks one of the 5 pillars?

39. Either: Write one way man becomes a true child of God.

Or: Why did Allah send Prophet Mohammed on earth?

40. Either: What title do we give the followers of Jesus?

Or: What title do we give to the followers of Mohammed?

SECTION B (60 MARKS)

41. (a) What is trade?

(b) Give three reasons why countries trade with each other.

(i) _____

(ii) _____

(iii) _____

42. (a) What are landlocked countries?

(b) Give one landlocked country in East Africa.

(c) Suggest 2 challenges faced by landlocked countries of East Africa while carrying out International trade.

(i) _____

(ii) _____

43. (a) Mention any two sources of water.

(i) _____

(ii) _____

(b) Suggest any 2 ways water sources are misused in East Africa.

(i) _____

(ii) _____

44. (a) What is vegetation?

(b) Give one economic importance of vegetation.

(c) Suggest any two ways of caring for vegetation.

(i) _____

(ii) _____

45. (a) Why did the British sign agreements in Uganda?

(b) Suggest 3 ways in which the 1900 Buganda Agreement affect the Buganda Kingdom.

- (i) _____
- (ii) _____
- (iii) _____

46. (a) Write EAC in full

(b) Where are the headquarters of East African Community?

(c) Give two reasons why the East African community was formed.

- (i) _____
- (ii) _____

47. (a) State the economic importance of Olduvai George to the government of Tanzania.

(b) Why is East Africa referred to as the cradle land of man kind?

(c) Suggest 2 uses of a dog to the early man.

- (i) _____
- (ii) _____

48. (a) What is the largest Ethnic group of people in East Africa?

(b) Suggest 3 reasons why people migrated long ago.

- (i) _____
- (ii) _____
- (iii) _____

49. (a) Write down 3 contributions of Arabs in East Africa.

- (i) _____
- (ii) _____
- (iii) _____

(b) In which way was Swahili culture formed?

50. (a) What are children's rights?

(b) State any two examples of children's rights you know.

(i) _____

(ii) _____

(c) Mention any one way children's rights are abused in East Africa today

For questions 51-55 answer Either Christianity Or Islam BUT not both in a number.

51. (a) Either: Who is a Prophet?

(b) Mention any two Prophets mentioned in the Bible.

(i) _____

(ii) _____

(c) How did Stephen meet his death?

Or: (a) Who is a Martyr?

(b) Why are there few Martyrs today?

(c) Give any two ways how a Muslim can overcome temptations.

(i) _____

(ii) _____

52. Either: (a) Who led the Israelites out of Egypt?

(b) Write down any two plagues God sent to the Egyptians before Israelites left.

- (i) _____
- (ii) _____

(c) Name Moses' brother who helped him to liberate the Israelites.

Or: (a) How is an Imam important in the Islamic faith?

(b) Write down any three obligatory prayers said by Muslims daily.

- (i) _____
- (ii) _____
- (iii) _____

53. Either: (a) What miracle did Jesus perform at Cana?

(b) Mention any two people whom Jesus raised from the dead.

- (i) _____
- (ii) _____

(c) Give any one reason why Jesus performed miracles.

Or: (a) Mention any four Prophets according to the Quran.

- (i) _____
- (ii) _____
- (iii) _____
- (iv) _____

54. Either: (a) What does the term "Gospel" mean?

(b) Write down any three books of Gospel in the Bible.

- (i) _____
- (ii) _____
- (iii) _____

55. Either: (a) Name the worshipping place for Christians.

(b) Give any one reason why Christians pray to God?

(c) Write down any two Christian names.

(i) _____

(ii) _____

Or: (a) what do we call the place of worship for Muslims?

(b) Give any one reason why Muslims pray to Allah.

(c) Write down any two Muslim names.

(i) _____

(ii) _____

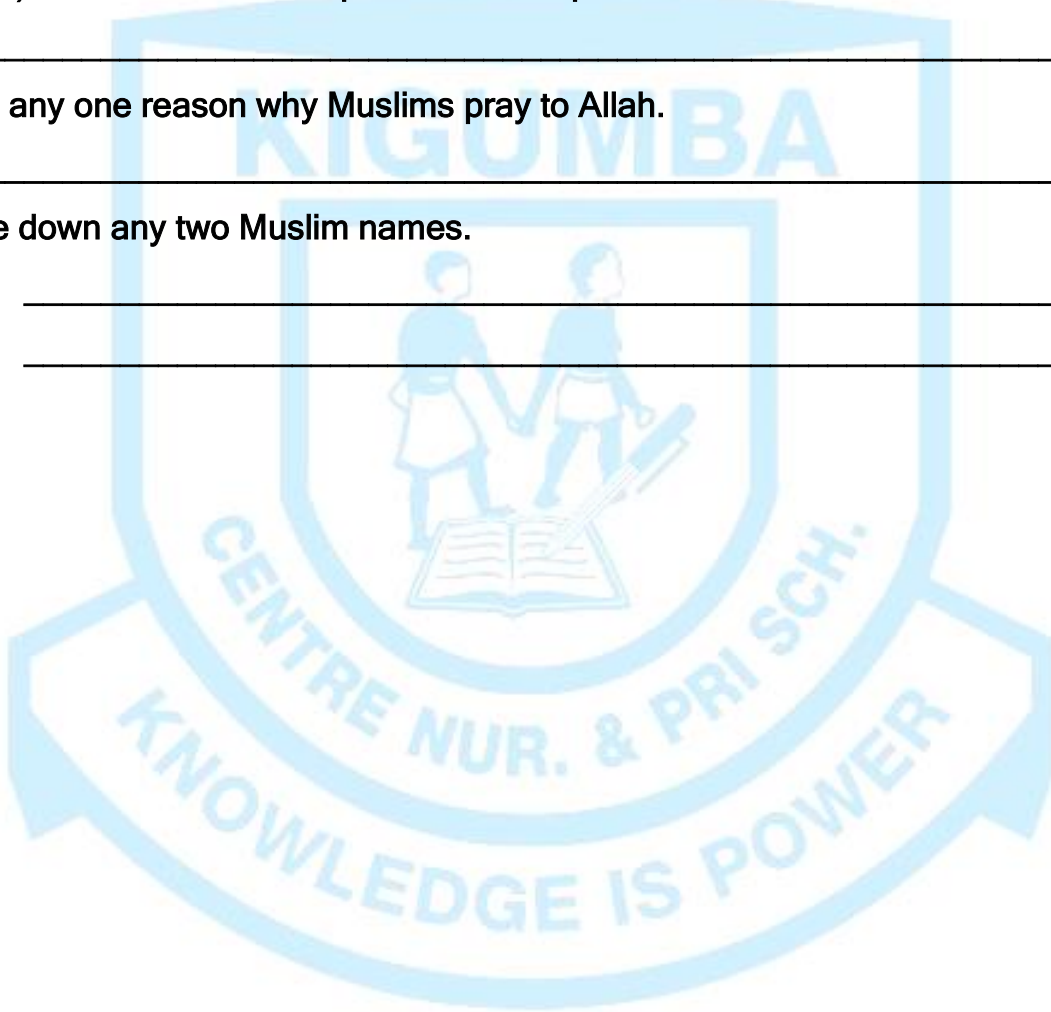



1st Term 2023 Holiday-Package

P.6 Integrated Science

Time allowed: 2 hours and 15 minutes

Name: _____ **Stream:** _____

SECTION A (40 marks):

1. Name the part of the plant used that makes food.

2. Give one reason why bees swarm.

3. State one similarity between birds and fish.

4. Why should food be cooked before eating it?

5. Name one breed of sheep reared for wool production.

Use the diagram below to answer question 6 and 7.

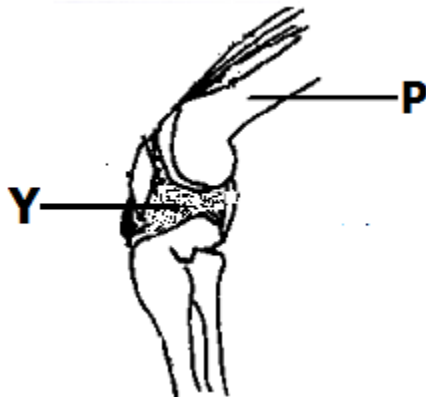

6. Name part labeled Y.

7. Apart from the knee, state any other part of the body where such a joint is found.

8. State one danger of too much rainfall.

9. Give the term used to describe a special structure where chicks are kept.

10. How can animals be used as energy resources?

11. Gundi's baby had a swollen moon face and brown hair. Name the deficiency disease Gundi's baby was suffering from.

12. State one human activity that degrades soil.

13. Give one reason why people take alcohol.

14. How do hookworm enter ones body?

15. What happens to light rays as they travel from one medium to another?

Use the diagram of the vector below to answer question 16 and 17.



16. Name the vector.

17.

Mention one disease spread by such a vector.

18. State one way animals depend on plants.

-
19. How does paddock grazing control tick in cattle?
-
20. Give one reason why parents are advised to take their children for immunisation?
-
21. If you were a father, why would you try very hard to avoid an extended family?
-
22. How are the incisor teeth useful to man?
-
23. Why are people warned against smoking in a public place?
-
24. Name one example of an electrolyte.
-
25. In the space provided, draw the blood cell that defends the body against germs.
-
26. When making charcoal, why is wood covered with soil?
-
27. Besides producing hormones, state any other function of the ovary in animals.
-

The diagram below shows one of the instruments used in measuring mass. Use it to answer questions 28 and 29.

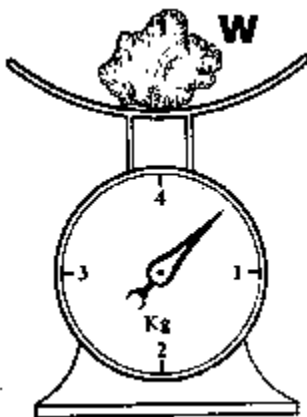

28. What is the mass of substance W?

29. Why can't the above instrument measure a mass of 7kg?

30. Mention the body organ that is affected by hepatitis.

31. What term is used to refer to drugs used to treat common diseases in a community?

32. Name any one product got from rabbits.

33. How are gills useful to a mushroom?

34. Give one example of a physical change.

35. Why is it advisable to cook from a raised place at home?

Below is a diagram of a bow harp. Use it to answer questions 36 and 37.

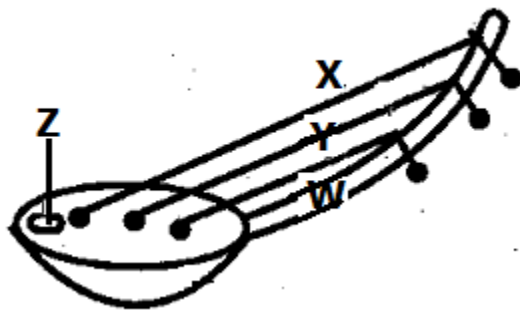

36. Which of the above string will produce low pitched sound?

37. How is part marked **z** useful in the above instrument?

38. Why is water regarded to be matter?

39. State one way you can care for a sick person.

40. In which part of the lung does gaseous exchange takes place?

Section B (60 marks)

41(a) Name the component of air which takes the largest percentage of air.

(b) State the property of air that enables a person to take a soda using a straw.

(c) Give one way in which air can be dangerous to man.

(d) Which component of air is produced during respiration?

42. **The diagram below shows an optical device. Use it to answer questions about it.**

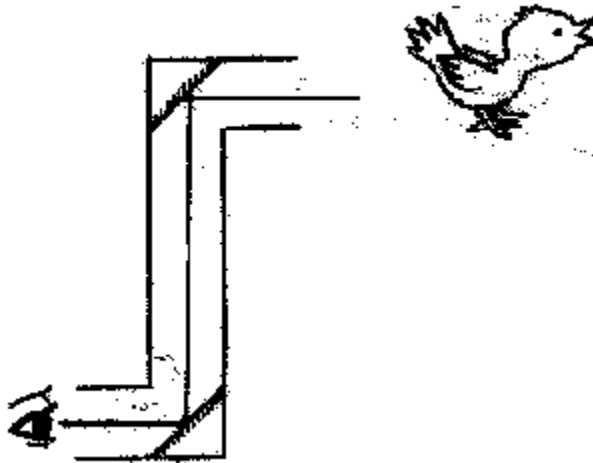

(a) Name the instrument shown above.

(b) State the type of mirror used in the device.

(c) Give one use of the device.

(d) What principle does the device above use to operate.

43(a) How is a latrine useful in a home?

(b) Why should there be a hand washing facility near a latrine?

(c) State the importance of a vent pipe on a VIP latrine.

(d) What is the danger of pouring chemicals in a pit latrine?

44(a) How does heat travel through a vacuum?

(b) Give a reason why the handle of a frying pan is made of wood.

(c) In which way is heat energy a danger to man?

(d) State the importance of having a fire extinguisher in a school.

45(a) Name the type of weather that make school children discover the use of a school sweater.

(b) What role does the sweater play during that weather?

(c) How is the sun useful in rain formation?

(d) Name the weather instrument used to measure the amount of rainfall received in an area.

46. The diagram below is of a fruit. Use it to answer questions about it.

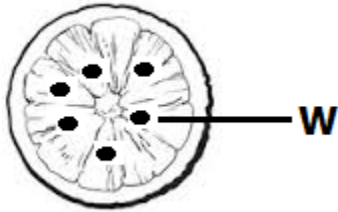

- (a) Name layer marked W.

- (b) Under what group of succulent fruits does the fruit above belong?

- (c) Give a reason to support your answer in (b).

- (d) How is the fruit likely to be dispersed?

47. The table below shows a food chain. Use it to answer questions about it.

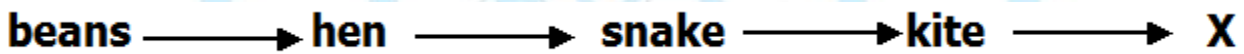

- (a) Name the producers.

- (b) Why is a snake called a secondary consumer?

- (c) Name one group of organisms represented by **x**.

- (d) How are such organisms important in the food chain?

- 48(a) Name two types of poultry kept in Uganda.
- (i) _____
 - (ii) _____
- (b) Give one purpose for keeping one of the types of poultry mentioned in (a) above.

- (c) State one disease caused by protozoa in poultry.

49. Below is an electric torch. Use it to answer questions about it.

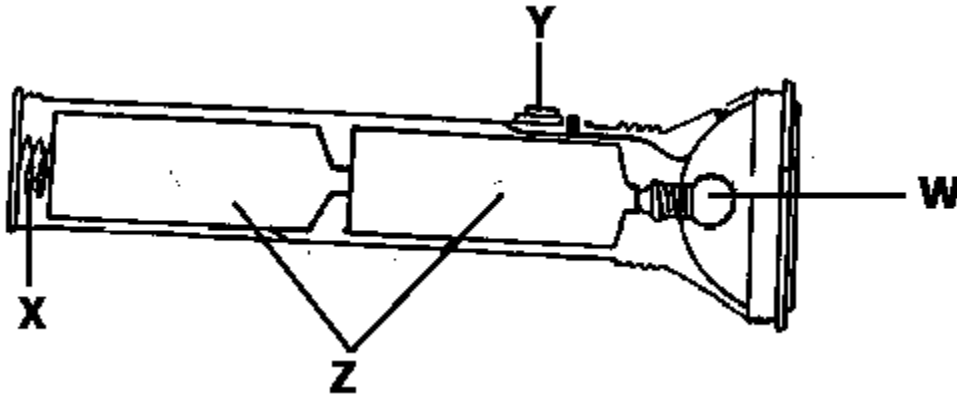

- (a) Name part labeled **X**.

- (b) State the function of part marked **Y**.

- (c) State one energy change at part **W** when the switch is closed.

- (d) Calculate the voltage in the torch.

- 50(a) Under what group of invertebrate is a snail?

- (b) How does a snail protect itself?

- (c) Give one danger of snail to man.

- (d) Why does a snail produce slime as it moves?

51. Match the items in list A to that in list B.

A

liver

lungs

B

uric acid

lactic acid

kidney
skin

bile juice
carbon dioxide

- (a) liver _____
- (b) lungs _____
- (c) kidney _____
- (d) skin _____

52. Juma was running a ten thousand metre race around the field, he suddenly collapsed.

- (a) What accident did Juma sustain that caused the collapsing?

- (b) What factor caused the accident mentioned in (a) above?

- (c) Imagine you are a first aider. What first aid would you give to Juma?

- (d) State one quality of a good first aider.

- 53(a) What happens to the food in the ileum?

- (b) How is the ileum adapted to its function?

- (c) Why is there no digestion in the colon?

- (d) Give one disorder of the digestive system.

- 54(a) State the element of PHC that checks on the population of a country.

- (b) Give the importance of water and sanitation as an element of Primary Health Care.

- (c) How can a family get involved in PHC?

- (d) Mention one principle of PHC.

55. **The diagram below shows a storage facility. Use it to answer questions about it.**



- (a) Name the facility.

- (b) How is the facility useful to farmers?

- (c) How is the structure adapted to controlling animal pests?

- (d) Why isn't it necessary for a tomato grower to have such a structure?

“The fear of the Lord is the beginning of wisdom”. Proverbs 1:7

Good luck and God bless you.